

Vulcan
vulcanlighting.co.za

Eclipse
Wash

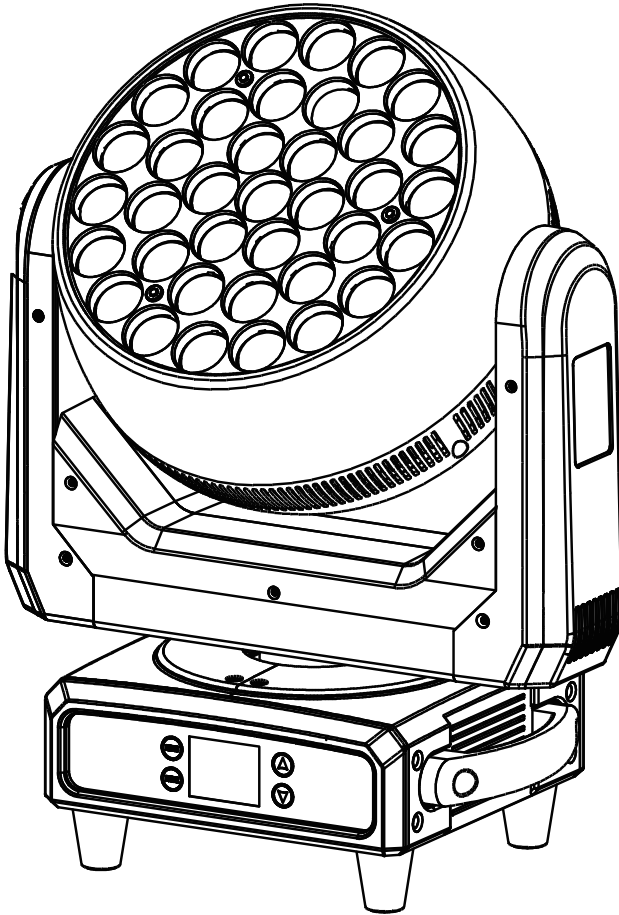

USER MANUAL

Please read the instructions carefully before use

directory

1. Safety guidance -----	1
2. Technical Specifications -----	3
3. control panel-----	5
4. Lighting installation -----	6
5. Fixture settings-----	8
5.1 Key features-----	8
5.2 Initial position adjustment-----	16
6. Universal DMX controller control -----	16
6.1 DMX512 connection -----	16
6.2 Address code settings -----	18
6.3 DMX512 channel -----	18
6.4 Product Lighting Diagram-----	26
7. error message -----	27
8. Troubleshooting -----	28
9. Equipment cleaning -----	29

1. Safety guidance



Please read this manual carefully, it includes important information such as installation, use, and maintenance.

Warnings

Please keep this manual as a basis for future inquiries, and if you sell this product to other users, please make sure they also get this manual.

note:

The equipment is packaged in good condition when it leaves the factory, please operate it according to the user manual, and the failure of the machine due to human reasons is not covered by the warranty.

- . Before using the product, please open it and inspect it carefully to ensure that the lamp is not damaged by transportation.
- . The device is only suitable for use in a dry room indoors.
- . The installation and operation of the lamps and lanterns should be carried out by professionals.
- . Do not allow small children to operate the machine.
- . Use a secure rope to secure the fixture, and hold up the bottom while moving the fixture.
- . The device must be installed in a well-ventilated place, at least 50 cm away from the adjacent plane.
- . Make sure the ventilation holes are clear to avoid overheating while the fixture is running.
- . Ensure that the supply voltage matches the supply voltage required by the equipment before operation.
- . Please ground the conductor to prevent electric shock.
- . Do not operate the lamp below 0°C or above 40°C.
- . It is forbidden to connect the luminaire directly to the dimming device.
- . A small amount of smoke or odor may occur when the new fixture is operating, which will disappear after 15 minutes of operation.
- . Do not place combustible materials next to the lamp when it is running, for fire risk.

- . Before turning on the lamp, please carefully check whether the power cord is broken, and replace it immediately if it is damaged.
- . The luminaire can operate at a surface temperature of up to 75°C, do not touch it with bare hands.
- . Avoid flammable liquids, water or metal and other electrical conductors from entering the inside of the lamp to avoid electric shock or fire, if there is any foreign object entering the lamp, please cut off the power immediately.
- . Avoid operating the lamps in dirty and dusty environments, and clean and maintain the lamps regularly.
- . It is forbidden to touch the wires when the lamp is running to prevent electric shock.
- . Avoid entanglement of the power cord with other wires.
- . The Distance Between The Luminaire and The Illuminated Surface Should BE Greater Than 0.5m.
- . Before replacing the fuse or bulb, disconnect the power supply.
- . Use the same model when replacing a fuse or bulb.
- . Do not turn the light on repeatedly.
- . If there is obvious damage to the lamp housing, lens or UV filter, please replace it in time.
- . There are no usable parts inside the lamp, so please do not open the lamp housing without permission.
- . If the machine fails, please stop using it immediately, and check it by power-off; Non-professional technicians, please do not repair by yourself; For assistance, please contact the nearest authorized sales/technical center.
- . When the lamp is not used for a long time or is repaired, please cut off the power supply.
- . When you need to transport it again, please use the original packaging materials.
- . There is a risk of explosion of high-temperature bulbs, do not turn on the light fixture within 15 minutes of power off.
- . Replace the bulb in time if it is damaged, deformed by heat, or has exceeded its service life.
- . Do not look directly at the lamp when it is running.
- . The bulb will be hot when the fixture is running, do not touch the bulb with your bare hands.

. Do not operate the lamp if it does not have a protective cover or if the housing is damaged.

note:

There are no parts inside the luminaire that can be used by the user. Don't just open the case, and don't repair it yourself. In the unlikely event that your fixture needs to be repaired, please contact your nearest dealer.

Installation :

The luminaire should be screwed to the quick-lock hook and be sure to be securely installed to prevent it from fluttering and slipping off during operation.

Also make sure that the structure of the connected luminaire is able to support 10 times the weight of the luminaire. Install the luminaire along with a safety rope that can support 12 times the weight of the luminaire.

The installation of the equipment should be carried out by professionals, and it should also be installed in a place that people cannot touch or pass by.

2. Technical Specifications

Input voltage range :

110-240V~ 50/60Hz

Power consumption :

500W

Light source :

37PCSx15W RGBW LED

Temperature :

6000K

Zoom range :

Zoom range : 5°-50°

PAN/TILT:

Pan movement: 540°

Tilt movement: 270°

16-bit precision scanning

Automatic Pan/Tilt position correction

Dimming/strobe:

0%~100% dimming stop/strobe effect with adjustable speed, dual channel with instantaneous power-off function for color temperature setting.

Strobe: 1 flash/sec., Fast strobe: 25 flashes/sec

control:

Control channels: 10/15/21/25/37/37+

Control protocol: DMX512, RDM

Upgrade: Upgrade via DMX/USB connection

structure:

4 touch buttons selection menu

Display: LED 2.4G color screen

Data in/out: 3-pin and 5-pin XLR

Power outlets: straight outlet, power connector input, power connector input/output.

Protection Rating: IP20

Key features:

Electronic linear zoom system

It integrates powerful beam and dyeing functions with excellent color macro effect

CTO: 2500K-8000K

Outstanding strobe effect with variable speed

2 fixed folding hooks for 50mm truss with keyhole reserved for 70mm truss for removable hooks

Maximum number of connections: 11 units at 230V and 50Hz, 5 units at 120V and 60Hz

Suitable for stages, theatres, TV studios and dance halls

Size/weight:

Product dimensions: 409x314x469mm

Package size: 490x350x620mm, 17kg(Carton included, one unit per carton)

The flight case is one for two: 750x440x700mm, 65kg(Flight case included)

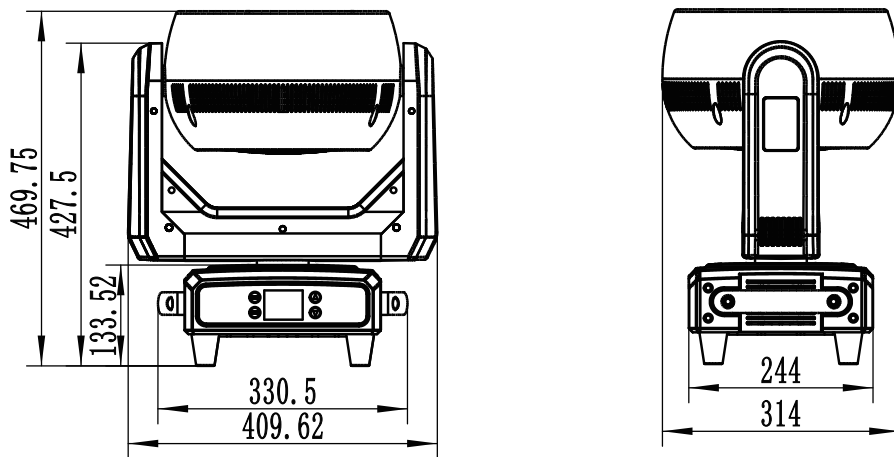

3. control panel

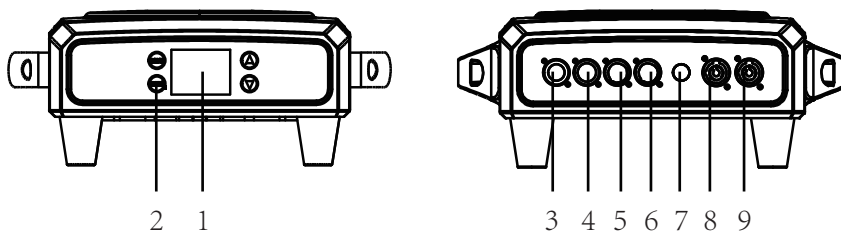

1. display screen: A menu of various functions is displayed

2. button:

MENU	Go to the menu to select the function
▲UP	to the previous option
▼DOWN	to the latter option
ENTER	Confirm the selected feature

3. 5-pin DMX input:

For DMX512 connection, use a 5-pin XLR cable to connect the luminaire to the DMX console and input the DMX signal

4. 3-pin DMX input:

For DMX512 connection, use a 3-pin XLR signal cable to connect the luminaire to the DMX console and input the DMX signal

5. 5-pin DMX output:

For DMX512 connection, use a 5-pin XLR cable to connect to the next fixture and output a DMX signal

6. 3-pin DMX output:

For DMX512 connection, use a 3-pin XLR cable to connect to the next luminaire and output a DMX signal

7. Fuse (T 10A): Protect luminaires from damage caused by excessive current or short circuits

8. Power input (POWERCON 1-in, 1-out version): Connect to a power supply

9. Power output (POWERCON 1-in, 1-out version): Connect the next fixture

4. Lighting installation

The installation of the equipment should be carried out by a professional and should also be installed in an area other than a walking path, seating area, or away from an area where the luminaire may be touched by unauthorized persons. When assembling, disassembling or repairing a luminaire, never stand directly underneath the luminaire.

When installing the fixture, make sure that the fixture is installed securely to prevent it from shaking and slipping off while running. It is also important to ensure that the structure of the fixture is able to support 10 times the weight of the luminaire without deformation. Install the fixture with a safety rope that can support 12 times the weight of the fixture to ensure that the fixture does not fall if the fixture fails.

The luminaire is fully operable in 3 different mounting positions: suspended upside down, mounted transversely on a truss, or placed on a flat horizontal surface. Always use and install the included safety rope as a safety measure to prevent accidental damage or death to the fixture in the event of a clamp failure.

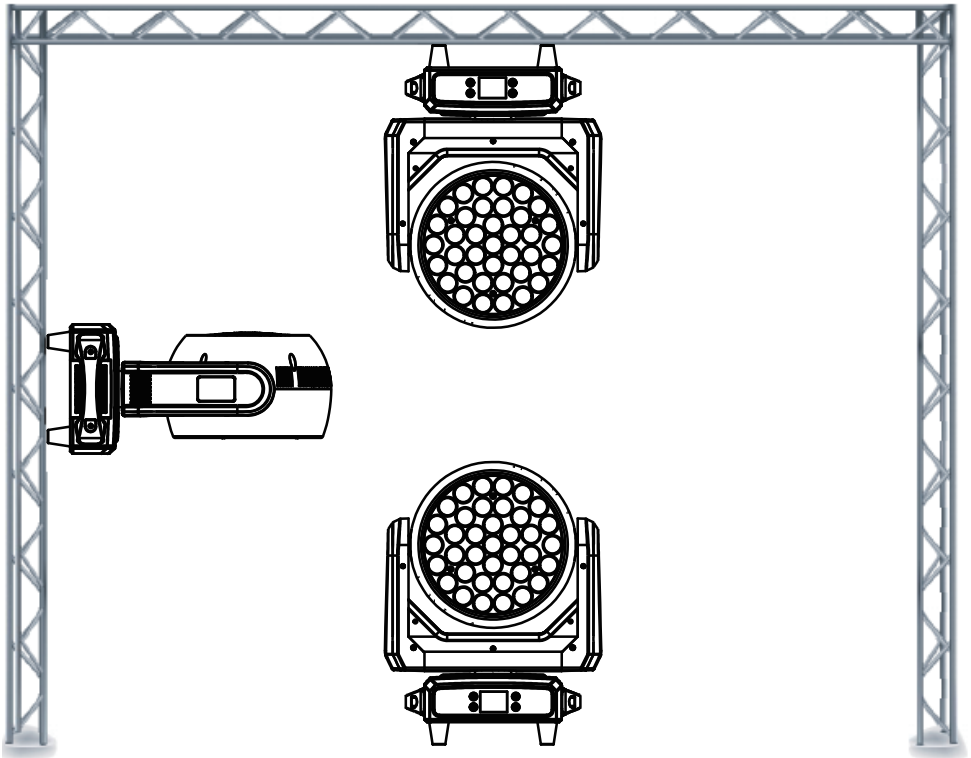

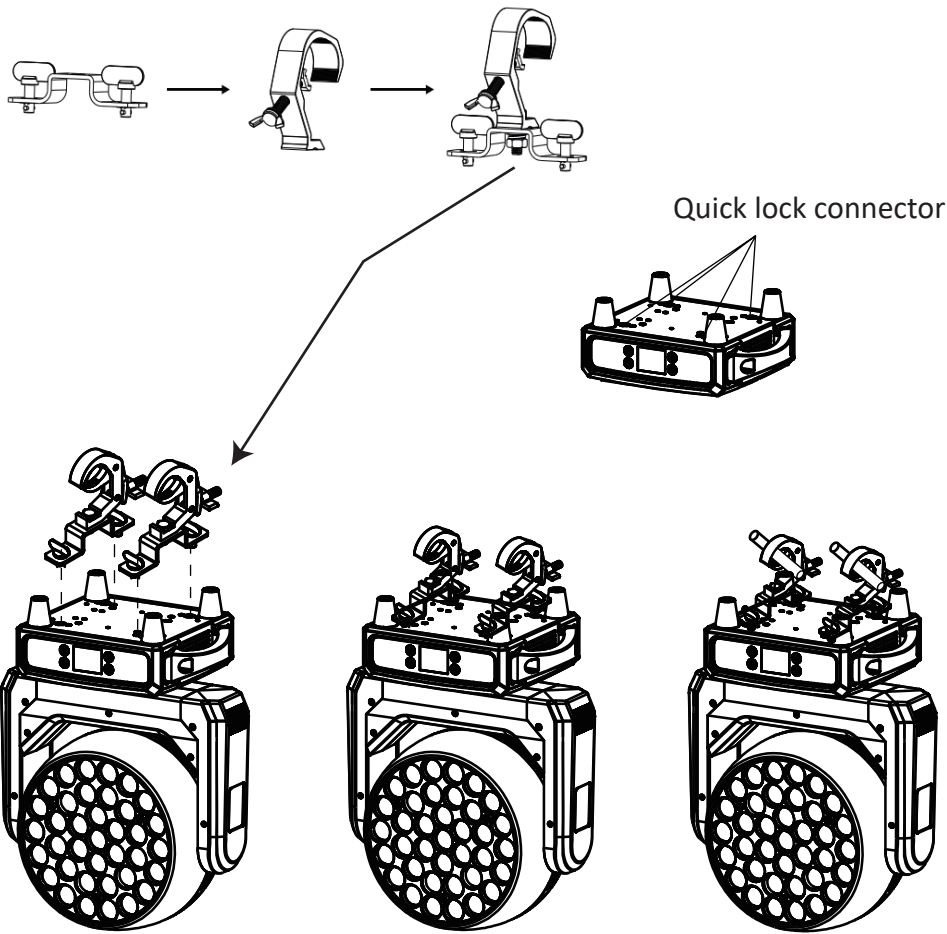

5. Fixture settings

5.1 Key features

Turn on the machine, press the MENU button to enter the menu mode, use the UP/DOWN button to find the menu, when the preset menu is displayed on the display screen, press the ENTER button to confirm, use the UP/DOWN button to select a submenu, press the ENTER button to save the settings or automatically return to the previous menu. Press the MENU button to go back, or wait/Leave for 30 seconds and then automatically exit menu mode. The main functions are shown below :

Main menu	submenu	Options		
DMX Functions	DMX Address	001		
		512		
	DMX Channel	Mode 1 (37)		
		Mode 2 (21)		
		Mode 3 (15)		
		Mode 4 (10)		
		Mode 5 (37+)		
		Mode 6 (25)		
	DMX State	Hold		
		BlackOut		
	View DMX Value	Pan	000-255	
		Pan Fine	000-255	
		Tilt	000-255	
		Tilt Fine	000-255	
		P/T Speed	000-255	
		Special Function	000-255	
		Red	000-255	
		Green	000-255	
		Blue	000-255	
		White	000-255	
CTO		000-255		
Color Macro		000-255		
Zoom		000-255		
Shutter		000-255		
Dimmer	000-255			
Fixture Settings	Pan Inverse	No		
		Yes		
	Tilt Inverse	No		
		Yes		
	P/T Feedback	No		
		Yes		
	White Balance	Red	125-255	
		Green	125-255	
		Blue	125-255	
	Dimmer Curve	Liner		
		Square		
Inv SQ				

		S Curve
	Dimmer Speed	Fast
		Smooth
Display Settings	Display Inverse	No
		Yes
		Auto
	Backlight Switch	Off
		On
	Backlight Intensity	1-10
	Temperature Unit	°C
		°F
Language	English	
	Chinese	
Fixture Test	Auto Test	
	Manual Test	
Fixture Information	Fixture use time	
	Firmware Version	
Reset	Pan/Tilt	No
		Yes
	Zoom	No
		Yes
	All	No
		Yes
Special Function	Factory Setting	
	Password	

DMX Functions

Enter the **MENU** mode, select the **DMX Function**, press the **ENTER** button to confirm, and use the **UP/DOWN** button to select: **DMX Address**, **DMX Channel**, **DMX State** or **View DMX Value**.

DMX Address

Select the **DMX address**, press the **ENTER** button to confirm, and the current **DMX address** will be displayed on the display. envoy Use the **UP/DOWN** button to select the 1-512 address and press the **ENTER** button to save. Press the **MENU** button to go back Go to the previous menu or wait for 1 minute to automatically exit the menu mode.

DMX Channel

Select **DMX Channel**, press the **ENTER** button to confirm, the current channel mode will be displayed on the display, use **UP/DOWN** button to select: **Mode 1 (37)**, **Mode 2 (21)**, **Mode 3 (15)**, **Mode 4 (10)**, **Mode 5 (37+)** or **Mode 6 (25)**, press the **ENTER** button to save. Press **MENU** press button to return to the previous menu or wait for 1 minute to automatically exit the menu mode.

DMX State

Select the **DMX State**, press the **ENTER** button to confirm, the current mode will be displayed on the display, and use the **UP/DOWN** button to select: **Hold** (the DMX signal stops and the machine will remain in the last state) or **Standby** (The DMX signal stops the machine and will go into standby mode), press the **ENTER** button to save. Press the **MENU** button to return to the previous menu or wait for 1 minute to automatically exit the menu mode.

View DMX Value

Select **View DMX Value**, press the **ENTER** button to confirm, the current channel and its value will be displayed on the screen. Use the **UP/DOWN** button to view additional channel values. Press the **MENU** button to return to the previous menu or wait for 1 minute to automatically exit the menu mode.

Fixture Settings

Enter **MENU** mode, select **Fixture Settings**, press the **ENTER** button to confirm, use the **UP/DOWN** button to select: **Pan Inverse**, **Tilt Inverse**, **P/T Feedback**, **White Balance**, **Dimmer Curve**, **Dimmer Speed**.

Pan Inverse

Select **Pan Inverse**, press the **ENTER** button to confirm, the current mode will be displayed on the display, use the **UP/DOWN** button to select: **No** (normal operation) or **Yes** (horizontal negation), press the **ENTER** button to save. Press the **MENU** button to return to the previous menu or wait for 1 minute to automatically exit the menu mode.

Tilt Inverse

Select **Tilt Inverse**, press the **ENTER** button to confirm, the current mode will be displayed on the display, use the **UP/DOWN** button to select: **No** (normal operation) or **Yes** (vertical negation), press the **ENTER** button to save. Press the **MENU** button to return to the previous menu or wait for 1 minute to automatically exit the menu mode.

P/T Feedback

Select **P/T Feedback**, press the **ENTER** button to confirm, the current mode will be displayed on the display, use the **UP/DOWN** button to select: **No** (X/Y will remain out of step when it is out of step) or **Yes** (X/Y will be out of step when it will be self Press **ENTER** to Save. Press the **MENU** button to return to the previous menu or wait for 1 minute to automatically exit the menu mode.

White Balance

Select **White Balance**, press the **ENTER** button to confirm, the current mode will be displayed on the display, use the **UP/DOWN** button to select: Red, Green or Blue, once selected, press the **ENTER** button to confirm. Use the **UP/DOWN** button to adjust the color brightness between 125-255, and press the **ENTER** button to save. Press the **MENU** button to return to the previous menu or wait for 1 minute to automatically exit the menu mode.

Dimmer Curve

Select **Dimmer Curve**, press the **ENTER** button to confirm, the current mode will be displayed on the display, use the **UP/DOWN** button to select: Linear, Squared, Inverse Squared or S-Curve, press the **ENTER** button to hold Exist. Press the **MENU** button to return to the previous menu or wait for 1 minute to automatically exit the menu mode.

Please refer to the figure below for details of the curves :

Dimmer Modes:

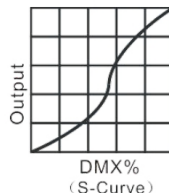
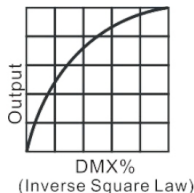
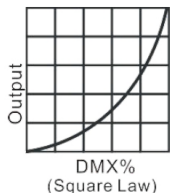
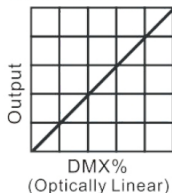

Dimmer Speed

Select the **Dimmer Speed**, press the **ENTER** button to confirm, the current mode will be displayed on the display, use the **UP/DOWN** button to select: fast or smooth, press the **ENTER** button to save. Press the **MENU** button to go back to the previous menu or wait for 1 minute to automatically exit the menu mode.

Display Settings

Enter the **MENU** mode, select the **Display Settings**, press the **ENTER** button to confirm, use the **UP/DOWN** buttons to select: **Display Inverse**, **Backlight Switch**, **Backlight Intensity**, **Temperature Unit** or **Language**.

Display Inverse

Select **Display Inverse**, press the **ENTER** button to confirm, the current mode will be displayed on the display, use the **UP/DOWN** button to select: **No** (Normal), **Yes** (Show Reverse), or Automatic, press the **ENTER** button to save. Press the **MENU** button to return to the previous menu or wait for 1 minute to automatically exit the menu mode.

Backlight Switch

Select **Backlight Switch**, press the **ENTER** button to confirm, the current mode will be displayed on the display, adjust the backlight by **UP/DOWN** button **OFF** or **ON**, press the **ENTER** button to save. Press the **ENTER** button to keep it Exist. Press the **MENU** button to return to the previous menu or wait for 1 minute to automatically exit the menu mode.

Backlight Intensity

Select **Backlight Intensity**, press the **ENTER** button to confirm, the current mode will be displayed on the display, use the **UP/DOWN** button to adjust the backlight brightness from **001** (black) to **010** (bright), press the **ENTER** button to save. Press the **ENTER** button to save. Press the **MENU** button to return to the previous menu or wait for 1 minute to automatically exit the menu mode.

Temperature Unit

Select the **Temperature unit**, press the **ENTER** button to confirm, the current mode will be displayed on the display, use the **UP/DOWN** button to select: **°C** or **°F**, press the **ENTER** button to save. Press the **MENU** button to go back on Level 1 menu or wait 1 minute to automatically exit menu mode.

Language

Select the **Language**, press the **ENTER** button to confirm, the current mode will be displayed on the display, use the **UP/DOWN** button to select: **English** or **Chinese**, press the **ENTER** button to save. Press the **MENU** button to return to the previous menu or wait for 1 minute to automatically exit the menu mode.

Fixture Test

Enter the **MENU** mode, select **Fixture Test**, press the **ENTER** button to confirm, and use the **UP/DOWN** button to select: **Auto Test** or **Manual Test**.

Auto Test

Select **Auto Test**, press the **ENTER** button to confirm, and the luminaire will run the built-in program to test horizontal, vertical, color wheel, dimming, strobe, zoom, focus, fogging, etc. Press the **MENU** button to go back to the previous menu or return to menu mode when the test is over.

Manual Test

Select **Manual Test**, press the **ENTER** button to confirm, and the current channel will be displayed on the display. Use the **UP/DOWN** button to select the channel, press the **ENTER** button to confirm, and then use the **UP/DOWN** button to adjust it Full channel value, press the **ENTER** button to save, and the fixture will run according to the channel value. Press the **MENU** button to return to the previous menu or wait for 1 minute to automatically exit the menu mode. (When you exit the manual test menu, all channel values will become zero).

Fixture Information

Enter the **MENU** mode, select **Fixture Information**, press the **ENTER** button to confirm, and use the **UP/DOWN** button to select: **Fixture use time** or **Firmware Version**.

Fixture use time

Select the **Fixture use time**, press the **ENTER** button to confirm, the time of the lamp will be displayed on the display, press the **MENU** button to exit.

Firmware Version

Select the **Firmware Version**, press the **ENTER** button to confirm, the CPU version of the device will be displayed on the display, press the **MENU** button to exit.

Reset

Enter the **MENU** mode, select **Reset** , press the **ENTER** button to confirm, and use the **UP/DOWN** button to select: **Pan/Tilt**, **Zoom** or **All** .

Pan/Tilt

Select **Pan/Tilt**, press the **ENTER** button to confirm, and use the **UP/DOWN** button to select: **No** or **Yes** (the machine will run the built-in program to restore the initial position both horizontally and vertically). Press the **ENTER** button to save. Press the **MENU** button to exit or wait 1 minute to exit menu mode.

Zoom

Select **Zoom**, press the **ENTER** button to confirm, Use the **UP/DOWN** buttons to select: **No** or **Yes** (the machine will run the built-in program to restore the initial position of the focus motor). Press the **ENTER** button to save. press **MENU** button to exit or wait 1 minute to exit menu mode.

All

Select **All**, press the **ENTER** button to confirm, Use the **UP/DOWN** buttons to select: **No** or **Yes** (machine running will run the built-in program to restore all motor initial positions). Press the **ENTER** button to save. press **MENU** button to exit.

Special Function

Enter the **MENU** mode, select Special Functions, press the **ENTER** button to confirm, and select: **Factory Setting** or **Password**.

Factory Setting

Select **Factory Setting**, press the **ENTER** button to confirm, use the **UP/DOWN** buttons to select: **No** (keep current settings) or **Yes** (restore factory settings), and once selected, press **ENTER** to save. Press the **MENU** button to exit.

Password

Select **Password**, press the **ENTER** button to confirm, use the **UP/DOWN** button to select: **000** or **999**, and once selected, press the **ENTER** button to save. Press the **MENU** button to exit.

5.2 initial position adjustment

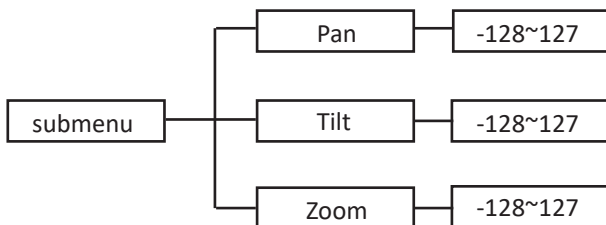

In the main function menu, press and hold the **ENTER** button for at least 3 seconds to enter the fine tuning menu, use the **UP/DOWN** button to select horizontal, vertical or zoom, and press the **ENTER** button to confirm. Use the **UP/DOWN** buttons to adjust the initial position of the horizontal, vertical, or zoom. Once confirmed, press the **ENTER** button to save. Press the **MENU** button to exit.

6. Universal DMX controller control

6.1 DMX512 connection

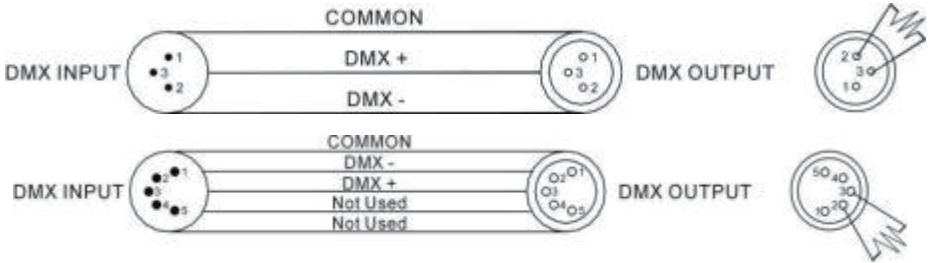
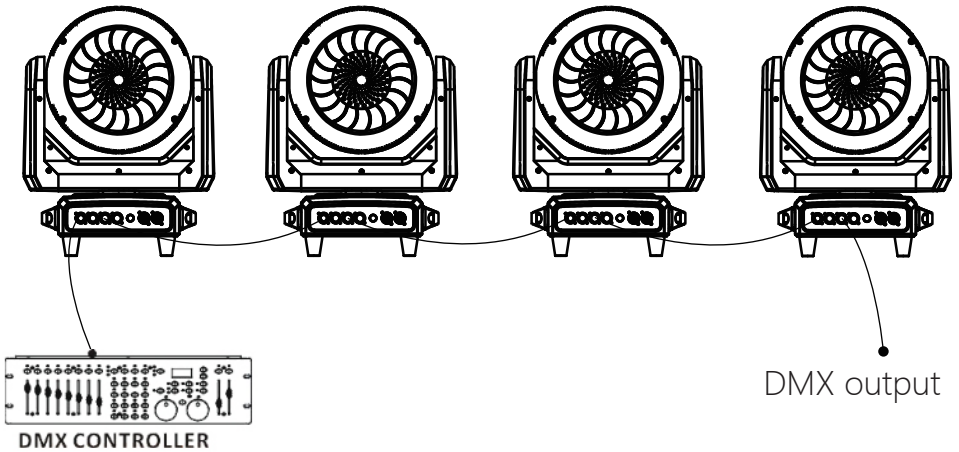

1. If you want to use a controller with a 5-pin DMX connector, you must use a 3-pin to 5-pin adapter signal socket.
2. On the last light, the DMX signal cable needs to be fitted with a terminator. Solder a 120ohm/4W resistor between pin2 and pin3, fit it into the 3-pin XLR plug and plug it into the DMX output of the last lamp.
3. Use an XLR signal cable to link the luminaire to the output port of the luminaire at one end and the input port of the next luminaire at the other end. XLR signal cables can only be used in series, not in parallel. The DMX512 has a fast signal transmission speed. Damaged signal lines, poor welding, poor contact, etc., will affect signal transmission and cause the system to shut down.
4. When the power supply of a unit is disconnected, the DMX output and input links are bypassed, so that the DMX line can continue to be connected.
5. Each lamp has an address code that can receive information from the console in the range of 0-512 (usually 0&1 and 1 are equal).
6. The terminals of the system need to be equipped with a terminator to reduce signal transmission errors.
7. 3-pin XLR connector connectors are a bit more common than 5-pin XLR.
3-pin XLR: PIN 1: GND, PIN 2: Negative, PIN 3: Positive.
5-core XLR: PIN 1: GND, PIN 2: Negative, PIN 3: Positive, PIN4/PIN5: Unused.

6.2 Address code settings

When using a universal DMX controller to control a fixture, you need to set the starting address (1-512) for the fixture so that the fixture can receive the signal. Press the **MENU** button to enter the menu mode, select the DMX function, press the **ENTER** button to confirm, select the DMX address, press the **ENTER** button to confirm, the current address will be displayed on the display, then use the **UP/DOWN** button to select the address code (1-512), press the **ENTER** button to save. Press the **MENU** button to return to the previous menu or wait for 1 minute to automatically exit the menu mode.

Please refer to the chart below to set the address code of the first 4 fixtures:

Channel mode	Lamps 1 Address code	Lamps 2 Address code	Lamps 3 Address code	Lamps 4 Address code
10 passage	1	11	21	31
15 passage	1	16	31	46
21 passage	1	22	43	64
25 passage	1	26	51	76
37 passage	1	38	75	112
37+ passage	1	38+	75+	112+

6.3 DMX512 channel

Please refer to the channel diagram below to control the fixture
note:

1. If the DMX signal is cut off, the fixture will remain in the state it was in before the signal was disconnected until it is set up again.
2. In the "Function" channel, hold the channel value for about 3 seconds and the fixture will run the corresponding function.

★ The strobe channel is only effective when the color macro & dimming is turned on.

10 channel mode (mode 4)

passage	Channel value	function
1	000-255	Pan
2	000-255	Pan Fine
3	000-255	Tilt
4	000-255	Tilt Fine
5	000-255	P/T Speed Fast and slow
6	000-009 010-014 015-019 020-049 050-059 060-069 070-079 080-089 090-099 100-109 110-139 140-149 150-179 180-189 190-199 200-209 210-239 240-243 244-255	Special Features Reserved Reserved Reserved Reserved Reserved Reserved Blackout while pan/tilt moving Disabled blackout while pan/tilt moving Reserved Reserved Reserved Pan/Tilt reset Reserved Zoom reset Reserved Total reset Reserved Disable "Silent mode" of fans "Silent mode of fans":fans noise from min. to max
7	000-015 016-247 248-255	Color macro function The overall control is from dark to bright Color change Built-in programs
8	000-255	Focus Wide and narrow

9	000-031 032-063 064-095 096-126 127-159 160-223 224-255	Strobe Darkfield Strobe 1: Slow and fast Strobe 2: The pulse is slow and fast Open the light Strobe 3: Turn off the pulse slowly Strobe 4: Burst pulse is slow and fast Open the light
10	000-255	Dimming 0%~100%

15 channel mode (mode 3)

passage	Channel value	function
1	000-255	Pan
2	000-255	Pan Fine
3	000-255	Tilt
4	000-255	Tilt Fine
5	000-255	P/T Speed Fast and slow
6	000-009 010-014 015-019 020-049 050-059 060-069 070-079 080-089 090-099 100-109 110-139 140-149 150-179 180-189 190-199 200-209 210-239 240-243 244-255	Special Features Reserved Reserved Reserved Reserved Reserved Reserved Blackout while pan/tilt moving Disabled blackout while pan/tilt moving Reserved Reserved Reserved Pan/Tilt reset Reserved Zoom reset Reserved Total reset Reserved Disable "Silent mode" of fans "Silent mode of fans":fans noise from min. to max

7	000-255	Built-in programs Red (0%-100%)
8	000-255	Green (0%-100%)
9	000-255	Blue (0%-100%)
10	000-255	White (0%-100%)
11	000-255	CTO
12	000-015 016-247 248-255	Color macro function Overall control Color change Built-in programs
13	000-255	Focus Wide and narrow
14	000-031 032-063 064-095 096-126 127-159 160-223 224-255	Strobe Darkfield Strobe 1: Slow and fast Strobe 2: Slow and fast Open the light Strobe 3: The pulse is slow and fast Strobe 4: Burst pulse is slow and fast Open the light
15	000-255	Dimming 0%~100%

21 channel mode (mode 2)

passage	Channel value	function
1	000-255	Pan
2	000-255	Pan Fine
3	000-255	Tilt
4	000-255	Tilt Fine
5	000-255	P/T Speed Fast and slow
6	000-009 010-014 015-019 020-049 050-059	Special Features Reserved Reserved Reserved Reserved Reserved

	060-069 070-079 080-089 090-099 100-109 110-139 140-149 150-179 180-189 190-199 200-209 210-239 240-243 244-255	Reserved Blackout while pan/tilt moving Disabled blackout while pan/tilt moving Reserved Reserved Reserved Pan/Tilt reset Reserved Zoom reset Reserved Total reset Reserved Disable "Silent mode" of fans "Silent mode of fans":fans noise from min. to max
7	000-255	Built-in programs Red (0%-100%)
8	000-255	Red Fine (16 Bit) (0%-100%)
9	000-255	Green (8 Bit) (0%-100%)
10	000-255	Green Fine (16 Bit) (0%-100%)
11	000-255	Blue (8 Bit) (0%-100%)
12	000-255	Blue Fine (16 Bit) (0%-100%)
13	000-255	White (8 Bit) (0%-100%)
14	000-255	White Fine (16 Bit) (0%-100%)
15	000-255	CTO
16	000-015 016-247 248-255	Color macro function Overall control Color change Built-in programs
17	000-255	Focus Wide and narrow
18	000-255	Focus Fine
19	000-031 032-063 064-095 096-126 127-159 160-223 224-255	Strobe Darkfield Strobe 1: Slow and fast Strobe 2: The pulse is slow and fast Open the light Strobe 3: Pulse off slow and fast Strobe 4: Burst pulse is slow and fast Open the light
20	000-255	Dimming 0%~100%
21	000-255	Dimming Fine 0%~100%

25 channel mode (mode 6)

passage	Channel value	function
1	000-255	Pan
2	000-255	Pan Fine
3	000-255	Tilt
4	000-255	Tilt Fine
5	000-255	P/T Speed Fast and slow
6		Special Features
	000-009	Reserved
	010-014	Reserved
	015-019	Reserved
	020-049	Reserved
	050-059	Reserved
	060-069	Reserved
	070-079	Blackout while pan/tilt moving
	080-089	Disabled blackout while pan/tilt moving
	090-099	Reserved
	100-109	Reserved
	110-139	Reserved
	140-149	Pan/Tilt reset
	150-179	Reserved
180-189	Zoom reset	
190-199	Reserved	
200-209	Total reset	
210-239	Reserved	
240-243	Disable "Silent mode" of fans	
244-255	"Silent mode of fans":fans noise from min. to max	
7	000-255	Built-in programs Red 1 Circle (8 Bit) (0%-100%)
8	000-255	Green 1 Circle (8 bit) (0%-100%)
9	000-255	Blue 1 Circle (8 Bit) (0%-100%)
10	000-255	White 1 Circle (8 bit) (0%-100%)
11	000-255	Red 2 Circle (8 Bit) (0%-100%)
12	000-255	Green 2 Circle (8 Bit) (0%-100%)
13	000-255	Blue 2 Circle (8 Bit) (0%-100%)
14	000-255	White 2 Circle (8 Bit) (0%-100%)
15	000-255	Red 3 Circle (8 Bit) (0%-100%)

16	000-255	Green 3 Circle (8 Bit) (0%-100%)
17	000-255	Blue 3 Circle (8 Bit) (0%-100%)
18	000-255	White 3 Circle (8 Bit) (0%-100%)
19	000-255	CTO
20	000-015 016-247 248-255	Color macro function Overall control Color change Built-in programs
21	000-255	Focus Wide and narrow
22	000-255	Focus Fine
23	000-031 032-063 064-095 096-126 127-159 160-223 224-255	Strobe Darkfield Strobe 1: Slow and fast Strobe 2: The pulse is slow and fast Open the light Strobe 3: Pulse off slow and fast Strobe 4: Burst pulse is slow and fast Open the light
24	000-255	Dimming 0%~100%
25	000-255	Dimming Fine 0%~100%

37 channel mode (mode 1)

passage	Channel value	function
1	000-255	Pan
2	000-255	Pan Fine
3	000-255	Tilt
4	000-255	Tilt Fine
5	000-255	P/T Speed Fast and slow

6	000-009	Special Features Reserved
	010-014	Reserved
	015-019	Reserved
	020-049	Reserved
	050-059	Reserved
	060-069	Reserved
	070-079	Blackout while pan/tilt moving
	080-089	Disabled blackout while pan/tilt moving
	090-099	Reserved
	100-109	Reserved
	110-139	Reserved
	140-149	Pan/Tilt reset
	150-179	Reserved
	180-189	Zoom reset
	190-199	Reserved
	200-209	Total reset
210-239	Reserved	
240-243	Disable "Silent mode" of fans	
244-255	"Silent mode of fans":fans noise from min. to max	
7	000-255	Focus Wide and narrow
8	000-255	Focus Fine
9	000-031	Strobe Darkfield
	032-063	Strobe 1: Slow and fast
	064-095	Strobe 2: Slow and fast
	096-126	Open the light
	127-159	Strobe 3: Pulse off slow and fast
	160-223	Strobe 4: Slow and fast
224-255	Open the light	
10	000-255	Dimming 0%~100%
11	000-255	Dimming Fine 0%~100%
12	000-255	CTO
13	000-015	Color macro function Overall control
	016-244	Color change
	245-255	Built-in programs
14	000-255	Built-in programs Red 1 Circle (8 Bit) (0%-100%)

15	000-255	Red Fine 1 Circle (16 Bit) (0%-100%)
16	000-255	Green 1 Circle (8 bit) (0%-100%)
17	000-255	Green Fine 1 Circle (16 Bit) (0%-100%)
18	000-255	Blue 1 Circle (8 Bit) (0%-100%)
19	000-255	Blue Fine 1 Circle (16 Bit) (0%-100%)
20	000-255	White 1 Circle (8 bit) (0%-100%)
21	000-255	White Fine 1 Circle (16 Bit) (0%-100%)
22	000-255	Red 2 Circle (8 Bit) (0%-100%)
23	000-255	Red Fine 2 Circle (16 Bit) (0%-100%)
24	000-255	Green 2 Circle (8 Bit) (0%-100%)
25	000-255	Green Fine 2 Circle (16 Bit) (0%-100%)
26	000-255	Blue 2 Circle (8 Bit) (0%-100%)
27	000-255	Blue Fine 2 Circle(16 Bit) (0%-100%)
28	000-255	White 2 Circle (8 Bit) (0%-100%)
29	000-255	White Fine 2 Circle (16 Bit) (0%-100%)
30	000-255	Red 3 Circle (8 Bit) (0%-100%)
31	000-255	Red Fine 3 Circle (16 Bit) (0%-100%)
32	000-255	Green 3 Circle (8 Bit) (0%-100%)
33	000-255	Green Fine 3 Circle (16 Bit) (0%-100%)
34	000-255	Blue 3 Circle (8 Bit) (0%-100%)
35	000-255	Blue Fine 3 Circle (16 Bit) (0%-100%)
36	000-255	White 3 Circle (8 Bit) (0%-100%)
37	000-255	White Fine 3 Circle (16 Bit) (0%-100%)

6.4 Product Lighting Diagram

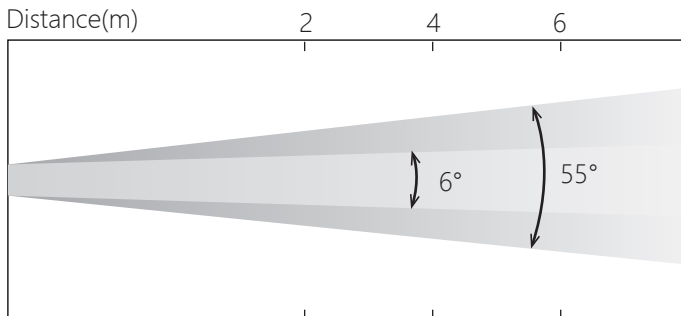

6°Lux	28000	7290	3280
Diameter(m)	0.48	0.70	0.93
55°Lux	5200	1520	670
Diameter(m)	2.3	4.5	6.6

7. error message

When there is an abnormality in the luminaire, the error warning will continue to be displayed on the display and will not disappear until the fault will be solved.

1. CPU-B/C/D error

Check that the 485(DATA) leads on the PCB board are in place or disconnected

Check that the 485 (DATA) lead is not broken

Check the associated signal circuit 485 (DATA) on the PCB for damage

2. Horizontal reset error

Check the position of the horizontally mounted magnet for detachment or damage

Check whether there are any other interfering items within the horizontal operating range

Check the horizontal Hall element for damage

Check the horizontal Hall element to the PCB board leads for poor contact or disconnection

Check the horizontal motor for damage

Check whether the relevant circuits of the horizontal motor drive board are damaged

3. Horizontal encoder error

Check the horizontal encoder for damage

Check the horizontal encoder-to-PCB board leads for poor contact or disconnection

4. Vertical reset error

Check whether the vertically mounted magnet position is detached or damaged

Check the vertical operating range for other interfering items

Inspect the vertical Hall element for damage

Check that the vertical Hall element to the PCB board leads are not in poor contact or disconnected

Check the vertical motor for damage

Check whether the circuits related to the vertical motor drive board are damaged

5. Vertical encoder error

Check if the vertical encoder is damaged

Check that the vertical encoder-to-PCB board leads are not in poor contact or disconnected

6. Color correction chip error

Check the chip for damage

Check whether the chip board is plugged in properly, and whether the IC and other electronic components are soldered

Check the motherboard for failures

Check whether the motherboard's R76 resistors and other components are soldered

7. Zoom reset error

Check the location of the zoom mounting magnet for detachment or damage

Check if there are any other interfering items in the zoom range

Check for damage to the scaled Hall component

Check that the scaled Hall component-to-PCB board leads are not in poor contact or disconnected

Check if the scaling motor is damaged

Check whether the circuits related to the scaling motor driver board are damaged

8. Lamp bead fan 1/2/3 error

Check if the fan is not running or if the fan voltage is measured correctly

Check that the fan leads are installed or disconnected

Check whether the fan circuit on the PCB board is abnormal

9. Base fan 1/2 error

Check if the fan is not running or if the fan voltage is measured correctly

Check that the fan leads are installed or disconnected

Check whether the fan circuit on the PCB board is abnormal

10. Head Fan 1/2/3 error

Check if the fan is not running or if the fan voltage is measured correctly

Check that the fan leads are installed or disconnected

Check whether the fan circuit on the PCB board is abnormal

11. Head temperature detection error

Check whether the temperature detection plate is normal

Check whether the components of the temperature detection board are damaged

Check that the temperature detection board leads are not disconnected

8. Troubleshooting

Here are some of the problems that often occur when the equipment is in operation, with some suggestions for troubleshooting:

A. The light fixtures are not working, there are no lights, and the fans are not turning

1. Check the power contact and the fuse is in good condition.
2. Detect voltage.
3. Check the indicator light of the power switch.

B. Not controlled by the console

1. Check that the DMX signal connector and signal cable are connected correctly.
2. Check if the address code is set correctly.
3. If the DMX signal transmission is intermittent, check that the XLR is well connected to the signal cable.
4. Try it with a different controller.
5. Check that the DMX signal line and the high-voltage wire are too close together, which could damage or interfere with the signal circuit.

C. A channel is out of order

1. The stepper motor or motor leads may be damaged.
2. The drive circuit of the motor may be damaged.

D. Light bulbs are sometimes good and bad

1. The bulb does not light properly. See if the voltage is too high or too low.
2. The internal temperature may be too high. If necessary, replace the refrigeration fan.

9. Equipment cleaning

Keeping the luminaires clean is absolutely essential in order to maintain optimal performance and ensure the best possible lighting results. It must be cleaned regularly. Luminaires, to avoid the accumulation of dust, dirt and smoke residues on the surface or inside the luminaires, cleaning frequency depending on the application environment. If dust enters the lamp due to the installation and construction environment, please clean it immediately to avoid excessive dust. Cause damage to the optical part of the lamp.

* It is recommended to use a soft, lint-free cloth and a high-quality glass cleaning solution, and no solvents should be used under any circumstances.

* Carefully wipe the parts.

* The outside of the lens must be wiped at least every 20 days. Wipe the inside at least every 30 days.